

CAMERON GREAT LAKES, INC.

MOLECULAR FILTRATION SPECIALISTS

SIDE ACCESS CARBON FILTER HOUSING

This rugged factory assembled housing can be stacked to accommodate any number of carbon trays that your air flow requires. It is available with a 2" or 4" pre filter track. A final track can be added when the system design requires it. Side access housings are also available in a one piece design with both pre and post filters, including 12" deep rigid box filters.

Outward turned 1 1/2 inch flanges make installation to the duct system simple and easy.

HOUSING FEATURES:

- Easy access from two sides.
- All metal to metal components sealed.
- Rugged construction of 16 gauge cold rolled steel.
- Fully gasketed, removable or hinged doors eliminating bypass of contaminated air.
- .32" W. G. resistance @ 500 fpm per 24" square face opening.

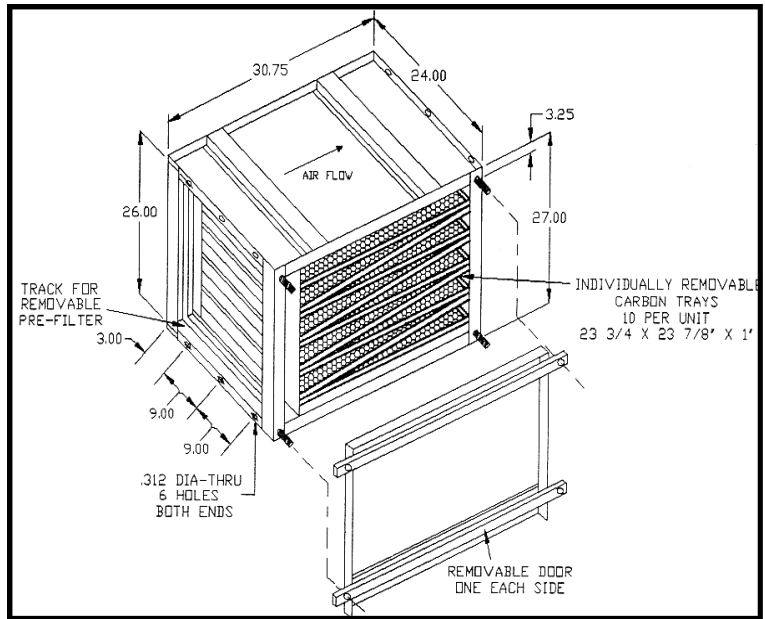

CARBON HOUSING DIMENSIONS											
H-high W-wide Based on pre-filter actual face size 23 5/8" x 23 5/8" and ten carbon trays per one-high housing											
1/2	H	15"	1	H	27"	1 1/2	H	42"	2	H	54"
2 1/2	H	69"	3	H	81"	3 1/2	H	96"	4	H	108"
1	W	24"	1 1/2	W	38 1/2"	2	W	50 1/2"	2 1/2	W	62 1/2"
3	W	74 1/2"	3 1/2	W	86 1/2"	4	W	98 1/2"	4 1/2	W	110 1/2"
5	W	122 1/2"	5 1/2	W	134 1/2"	6	W	146 1/2"			

Housing depths: 2" pre-filter-30 3/4", 4" pre-filter- 34 3/4".

Note: Add 1 1/2" to W for each door.

CGL warrants that these units are manufactured in accordance with the specifications disclosed herein. No warranty, expressed purpose or implied, is made relating to the suitability of the product for any particular application or purpose. Do not use dimensions for construction unless drawing is marked "Certified" by CGL.

2335 NW 29TH AVENUE, PORTLAND, OR 97210
 PHONE: (800) 777-4044 FAX: (503) 225-0137

WWW.CAMERONGREATLAKES.COM
 EMAIL: SALES@CGLCARBON.COM